

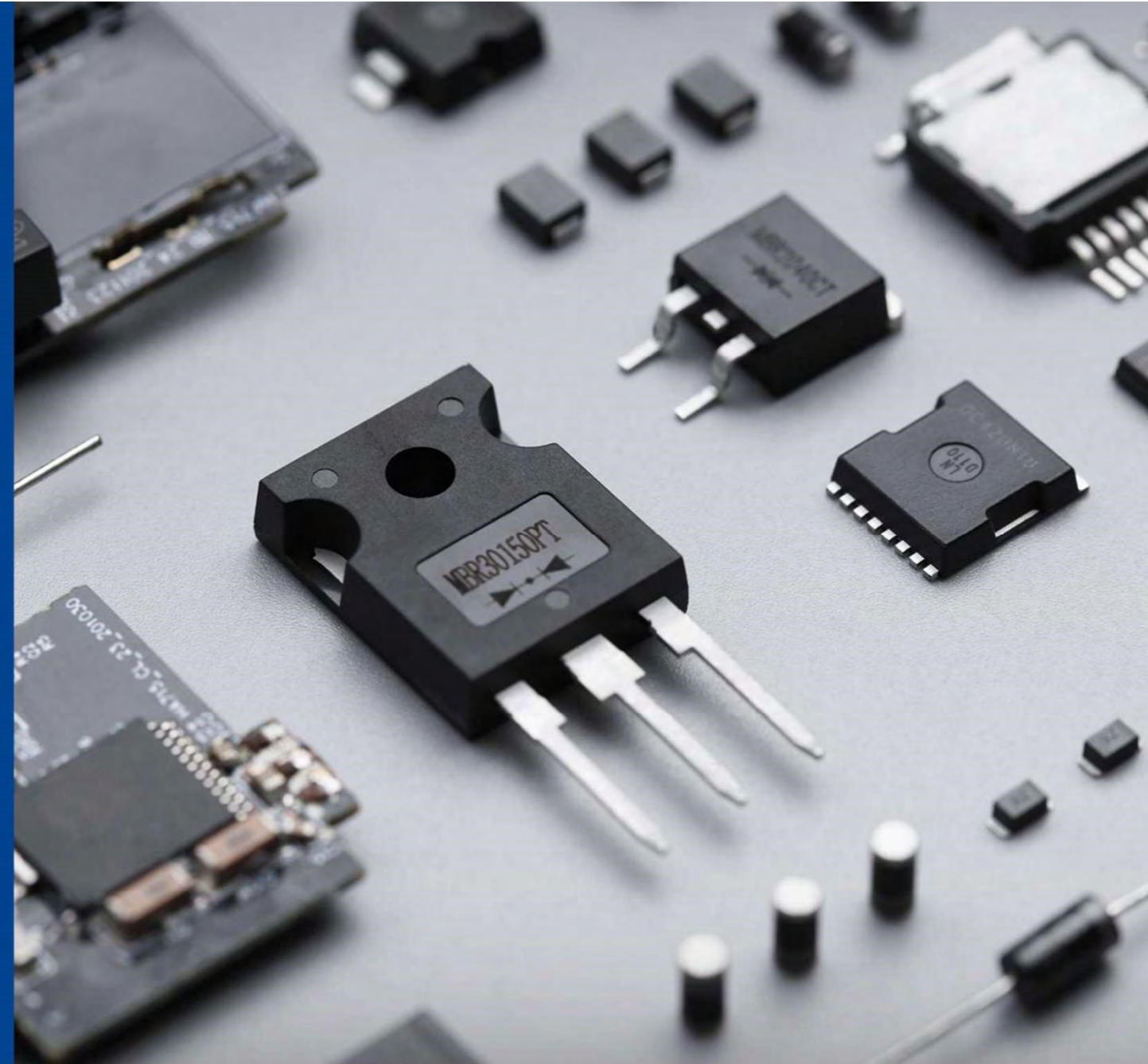

# HOLY STONE SEMICONDUCTOR PORTFOLIO

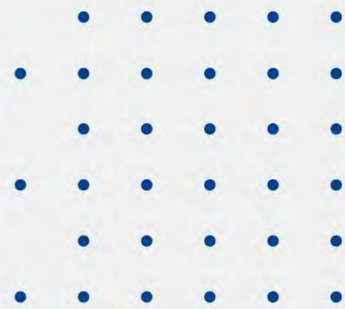

A PARTNER YOU CAN TRUST | [www.holystone.com.tw](http://www.holystone.com.tw)



# HOLYSTONE ENTERPRISE CO., LTD.



## Passive Components

Own factory

**IHEC**

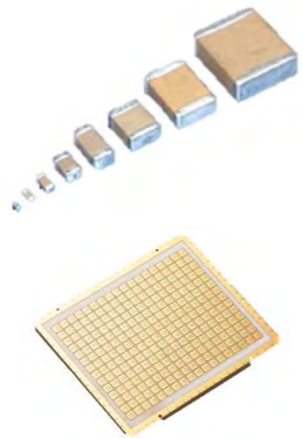

## Semiconductor

Subsidiary

**EETI**



Cooperation

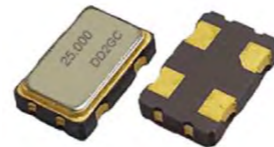

Close Partner



## Investment

Investment/Partner

**GSI TECHNOLOGY**



Investment/Partner

**WoMaster**







# HOLY STONE ENTERPRISE



Sales revenue in thousand USD

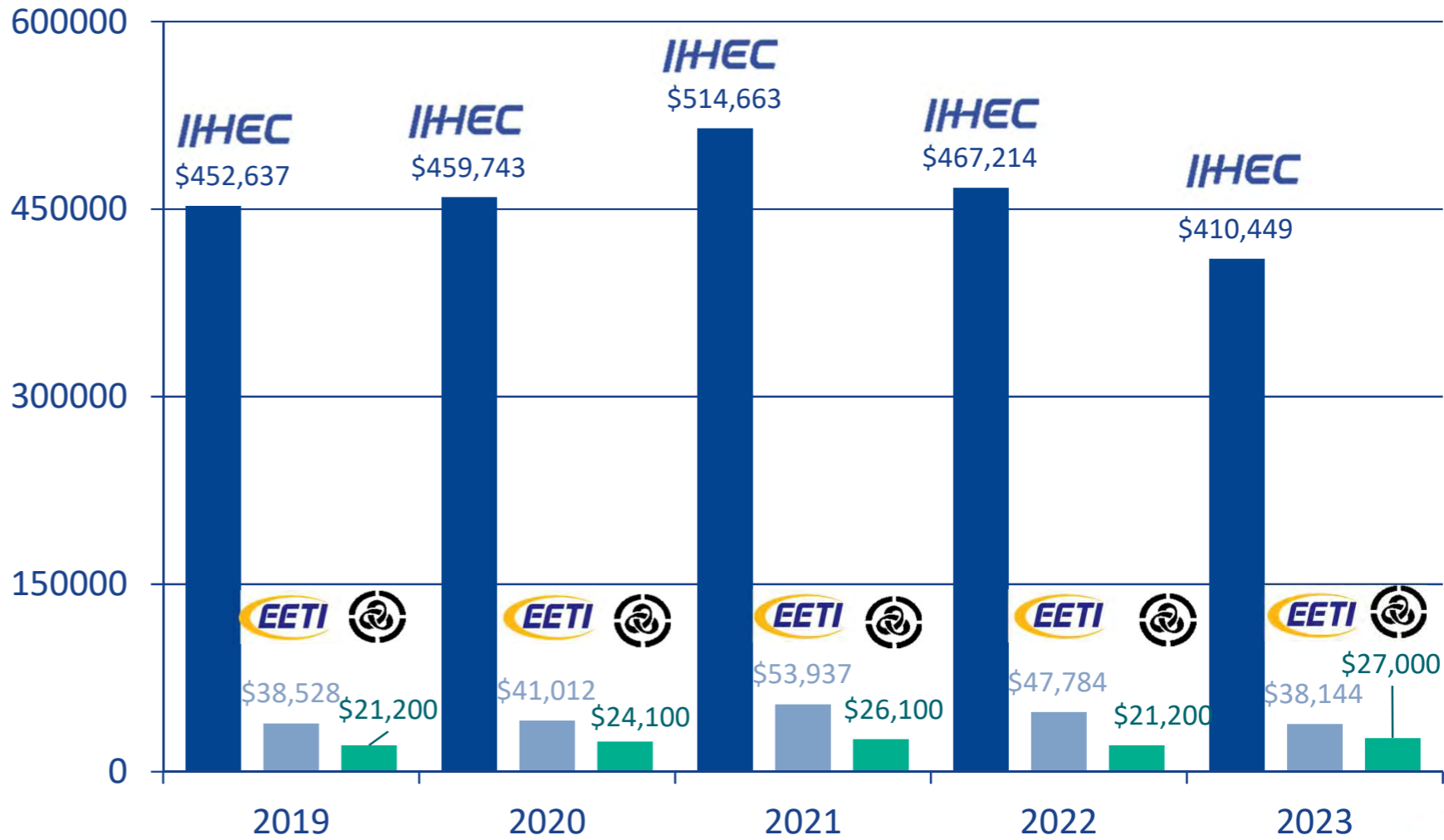





# FORMOSA MICROSEMI

HOLY STONE'S SEMICONDUCTOR PARTNER  
FOR DISCRETE COMPONENTS

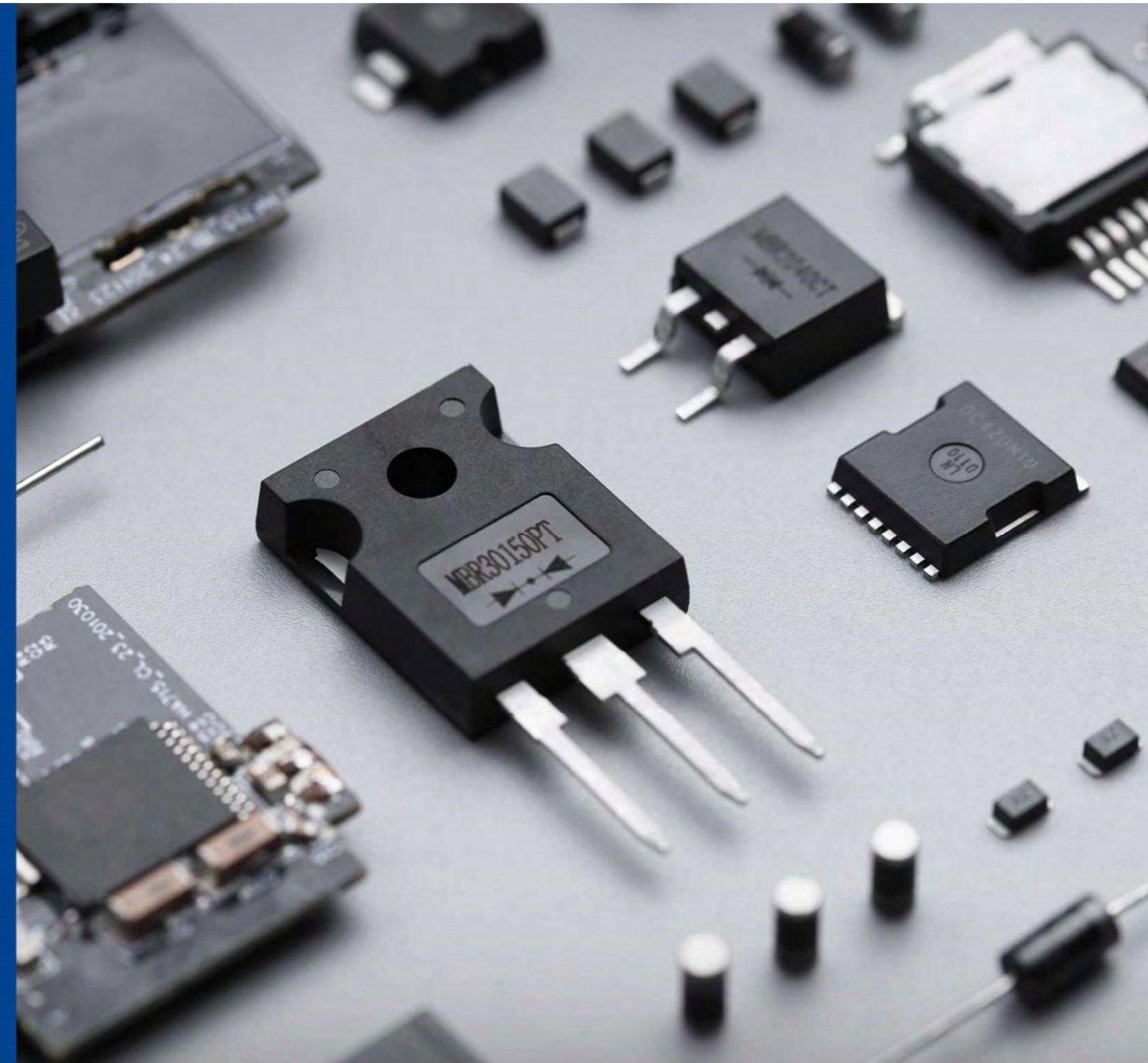

A PARTNER YOU CAN TRUST | [www.holystone.com.tw](http://www.holystone.com.tw)

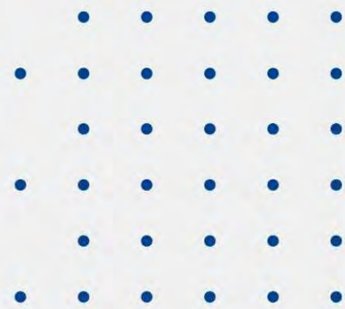



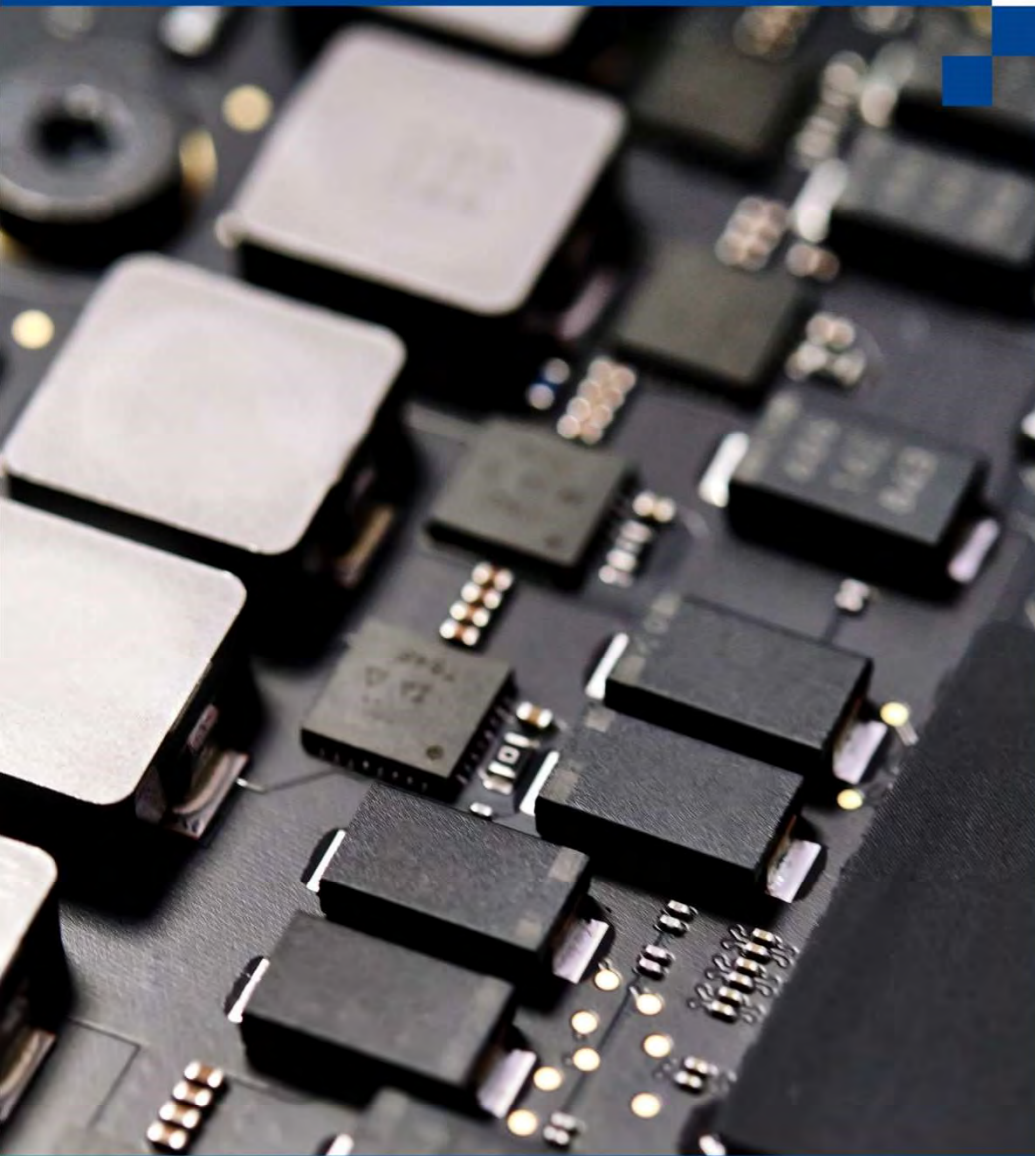

## FORMOSA MICROSEMI [FMS]



Founded in 1996 – more than 25 years experience

110 employees (20% R&D)

Discrete Semiconductors

Design and backend operation

Production facility (Taiwan, Yilan)

ISO9001, ISO14001, IATF16949



# FORMOSA MICROSEMI REVENUE SPLIT

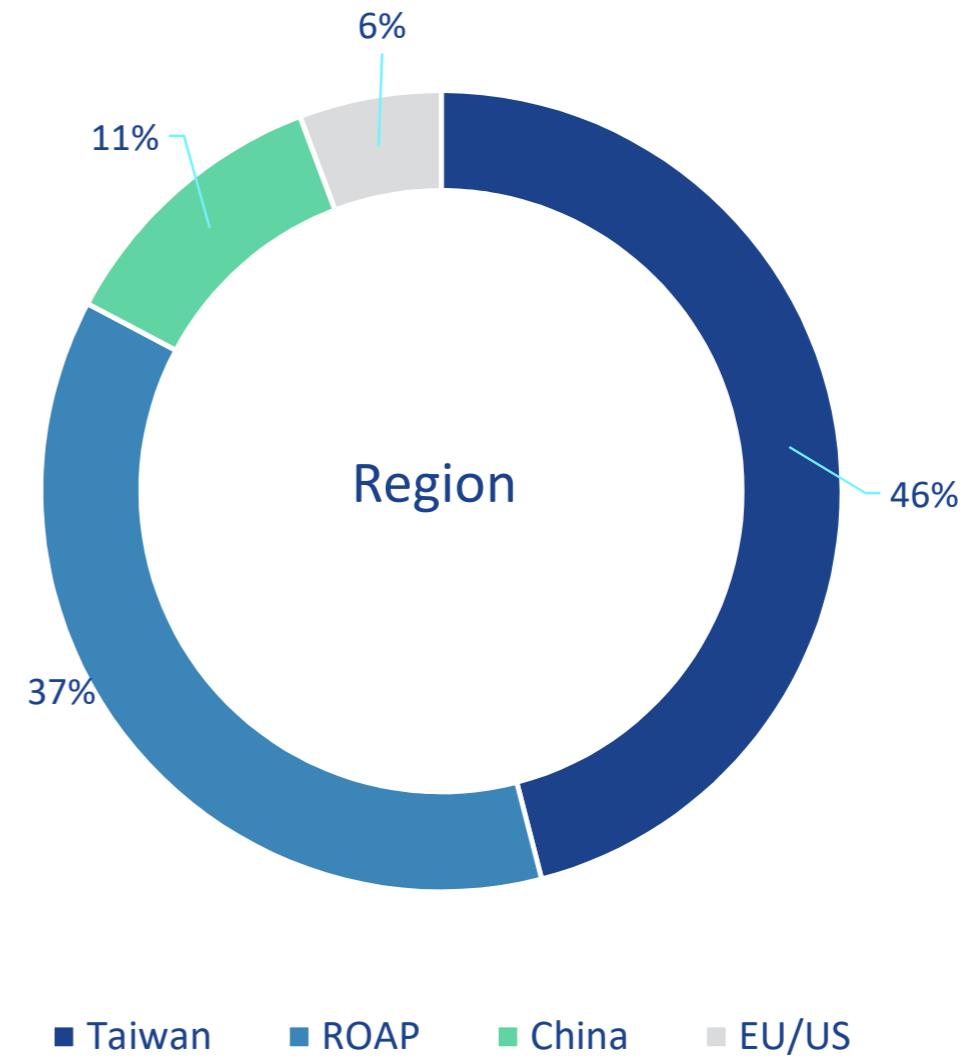
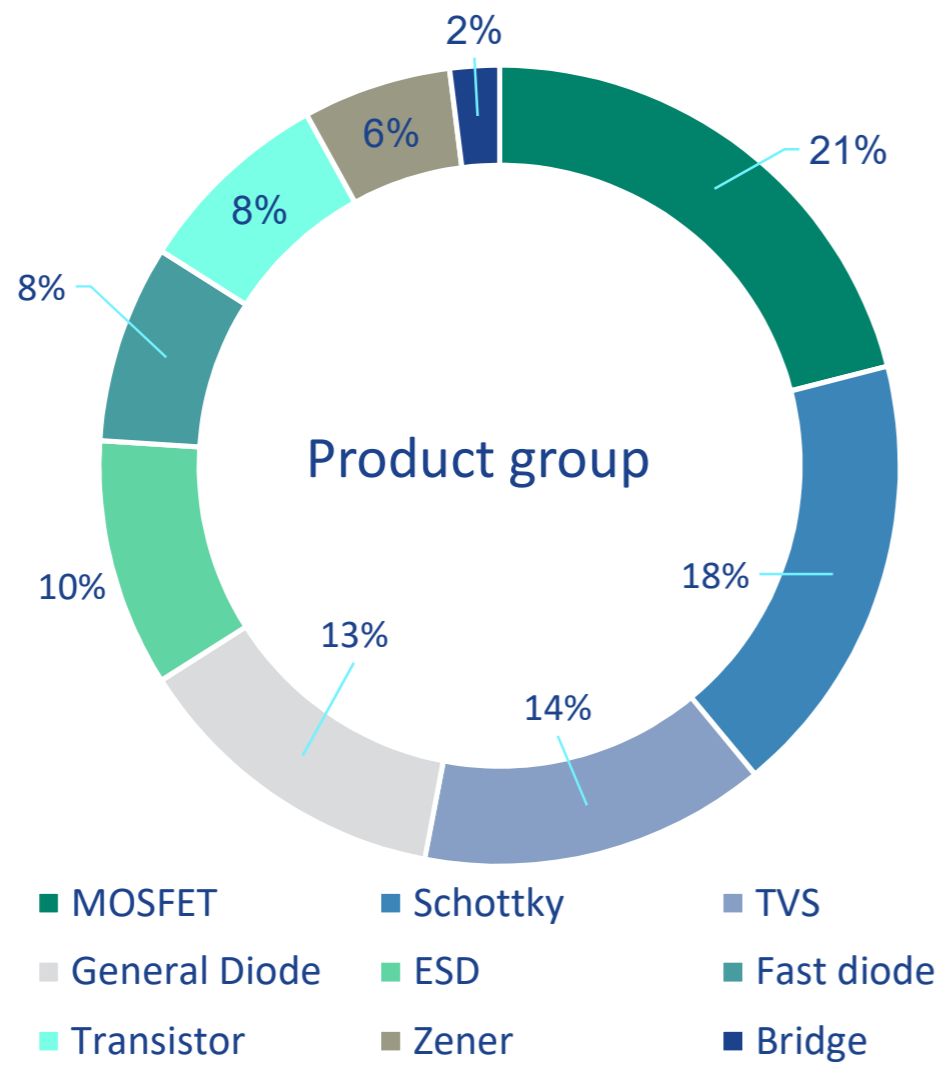





# PRODUCT PORTFOLIO

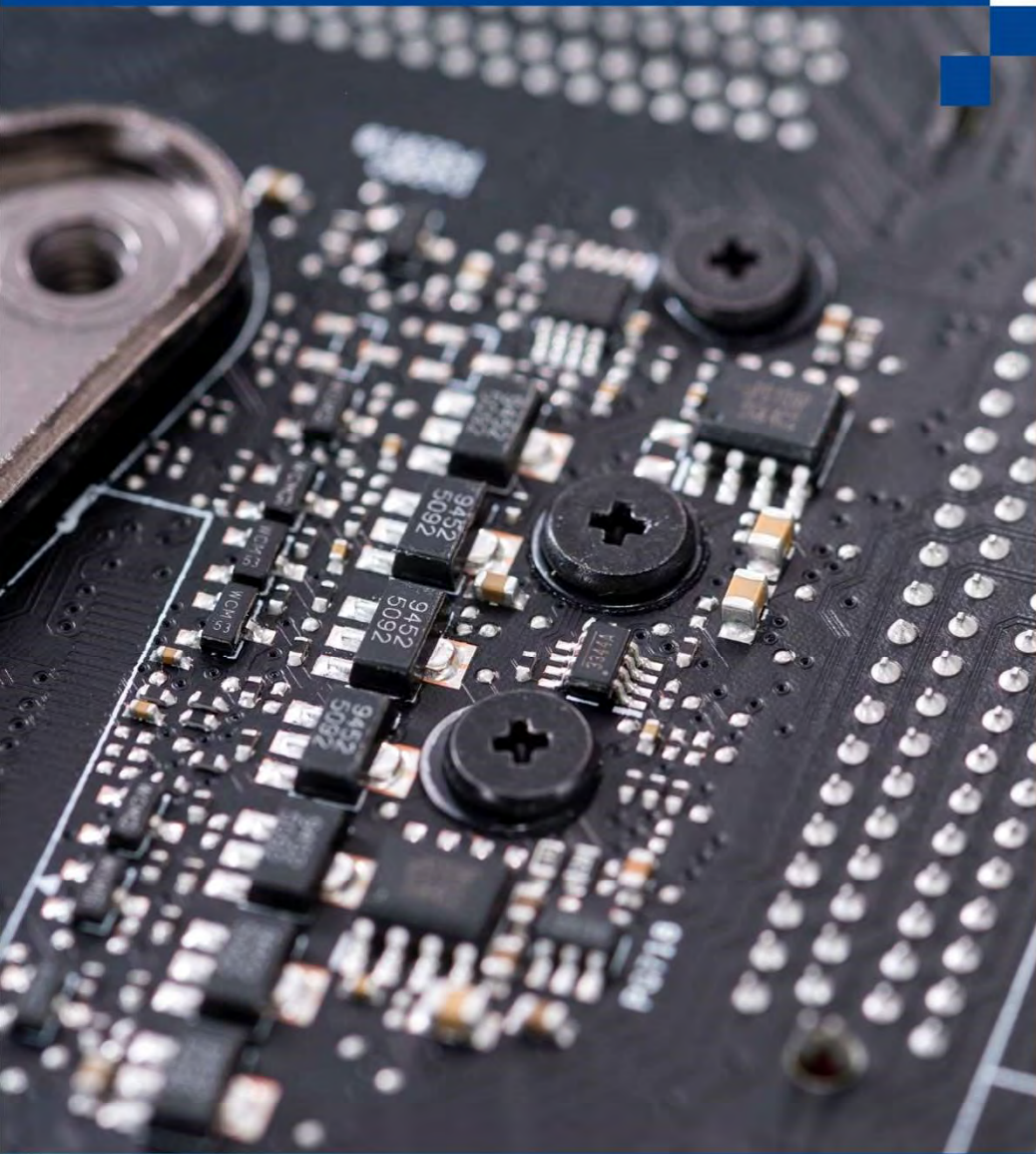

- |   |                  |   |                              |
|---|------------------|---|------------------------------|
|    | Rectifier diode  |    | Transistor                   |
|    | Schottky diode   |    | Digital transistor           |
|    | Switching diode  |    | Thyristor surge suppressor   |
|   | Zener diode      |   | MOSFET                       |
|  | TVS              |  | TRIAC                        |
|  | SiC diode        |  | Silicon controlled rectifier |
|  | Bridge rectifier |  | Gas discharge tube           |
|  | ESD              |   |                              |







# DIODE PORTFOLIO

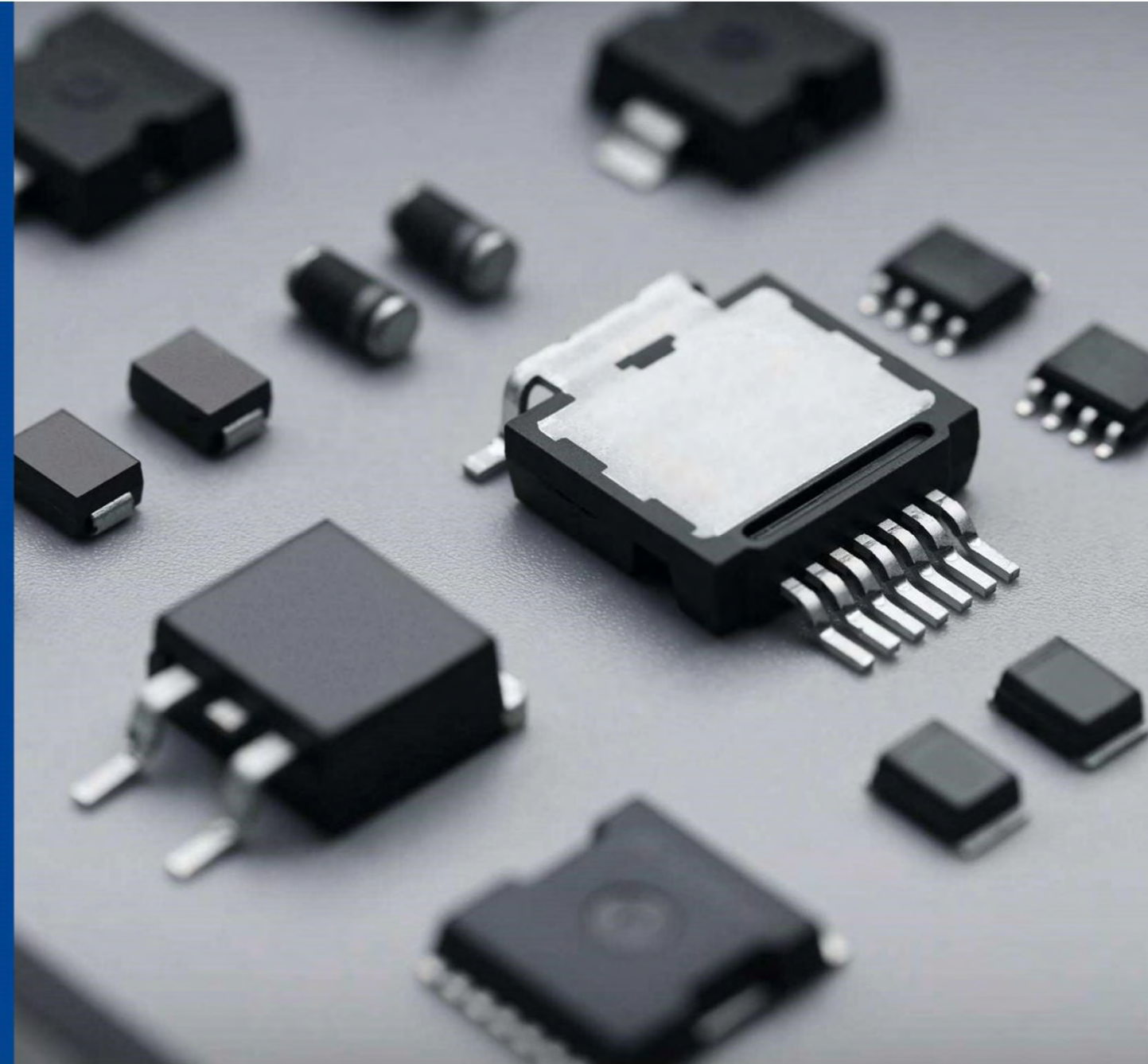

A PARTNER YOU CAN TRUST | [www.holystone.com.tw](http://www.holystone.com.tw)

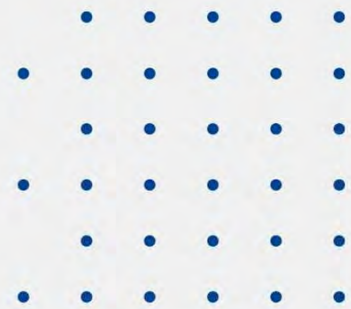



# PACKAGE PORTFOLIO RECTIFIER DIODES SMT



				
<b>SOD-323FLT</b> 2.8 x 1.5 x 0.88 mm	<b>SOD-123ST</b> 3.9 x 2.0 x 1.0 mm	<b>SOD-123HT</b> 3.7 x 1.8 x 0.85 mm	<b>SOD-123NT</b> 3.7 x 1.8 x 1.0 mm	<b>SMA-NT</b> 5.2 x 2.5 x 1.6 mm
				
<b>SMA-HST</b> 5.4 x 2.8 x 1.05 mm	<b>SMC-T3</b> 6.7 x 4.7 x 1.7 mm	<b>TO-277B</b> 6.7 x 4.3 x 1.3 mm	<b>TO-252 / DPAK</b> 10.3 x 6.7 x 2.5 mm	<b>TO-263 / D2PAK</b> 15.3 x 10.4 x 4.46 mm
				
<b>LFPAK5060</b> 6.25 x 1.3 x 1.12 mm	<b>TOLL-8L</b> 11.7 x 10 x 2.3 mm	<b>T2PAK-7P</b> 18.35 x 13.85 x 3.4 mm	<b>ASM-10A</b> 11.47 x 8.96 x 3.38 mm	

## Features

- Low profile high versions available
- AEC-Q101 qualified
- Space saving packages
- Fast and efficient performance

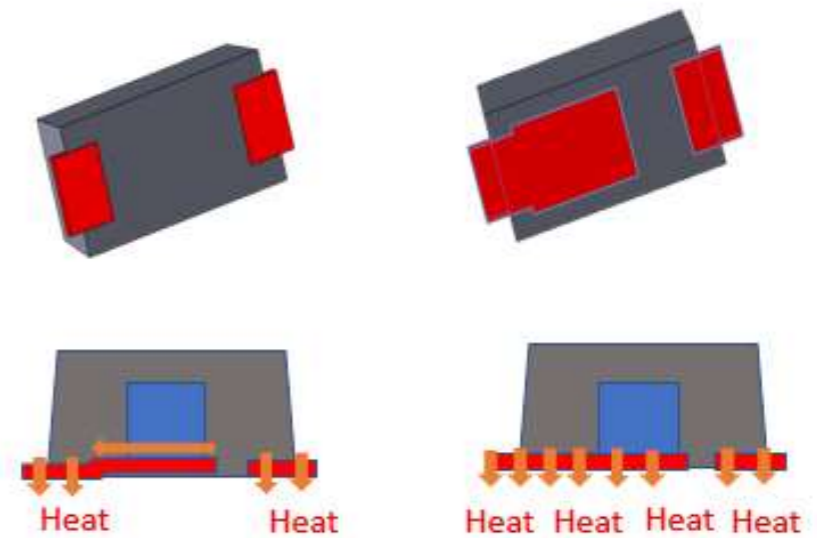

# PACKAGE PORTFOLIO PROTECTION DEVICES



TVS  
Schottky  
Zener

Series	SM6NT22	SMAK5NT	SMB15FL	5.0SMCJ	SM8S	ASM7.5KP
Package	SOD-123NT	DO-214AC SMA-NT	DO-214AA SMB-FL	DO-214AB SMC	DO-218	ASM
$V_{RWM}$	22~440V	40~800V	5~440V	11~170V	10~43V	10~48V
$P_{PP}$	600W	1500W	1500W	5000W	6600W	7500W

Series	P4KE	P6KE	1.5KE	30KPA
Package	DO-41	DO-15	DO-201AE	P600
$V_{RWM}$	5.8~378V	5.8~510V	5.8~376V	28~288V
$P_{PP}$	400W	600W	1500W	30000W



# PROTECT YOUR ELECTRONICS WITH HOLY STONE TVS DIODES



## Broad Range of Products

Holy Stone's portfolio covers the broadest range of TVS diodes in the market.

- Power handling: 200W until 30kW
- Voltage range: 5V until 513V

## Market analysis of SMAJ series (example)

Parameter	Holy Stone/FMS	Vixx	Dixx	Lixx	MCxx	TSxx
Voltage $V_{RMW}$	5V – 440V	5V – 188V	5V – 170V	5V – 440V	5V – 440V	5V – 188V
$P_{PPM}$ (10/1000us)	600W	400W	600W	400W	400W	400W



# ESD PROTECTION PORTFOLIO

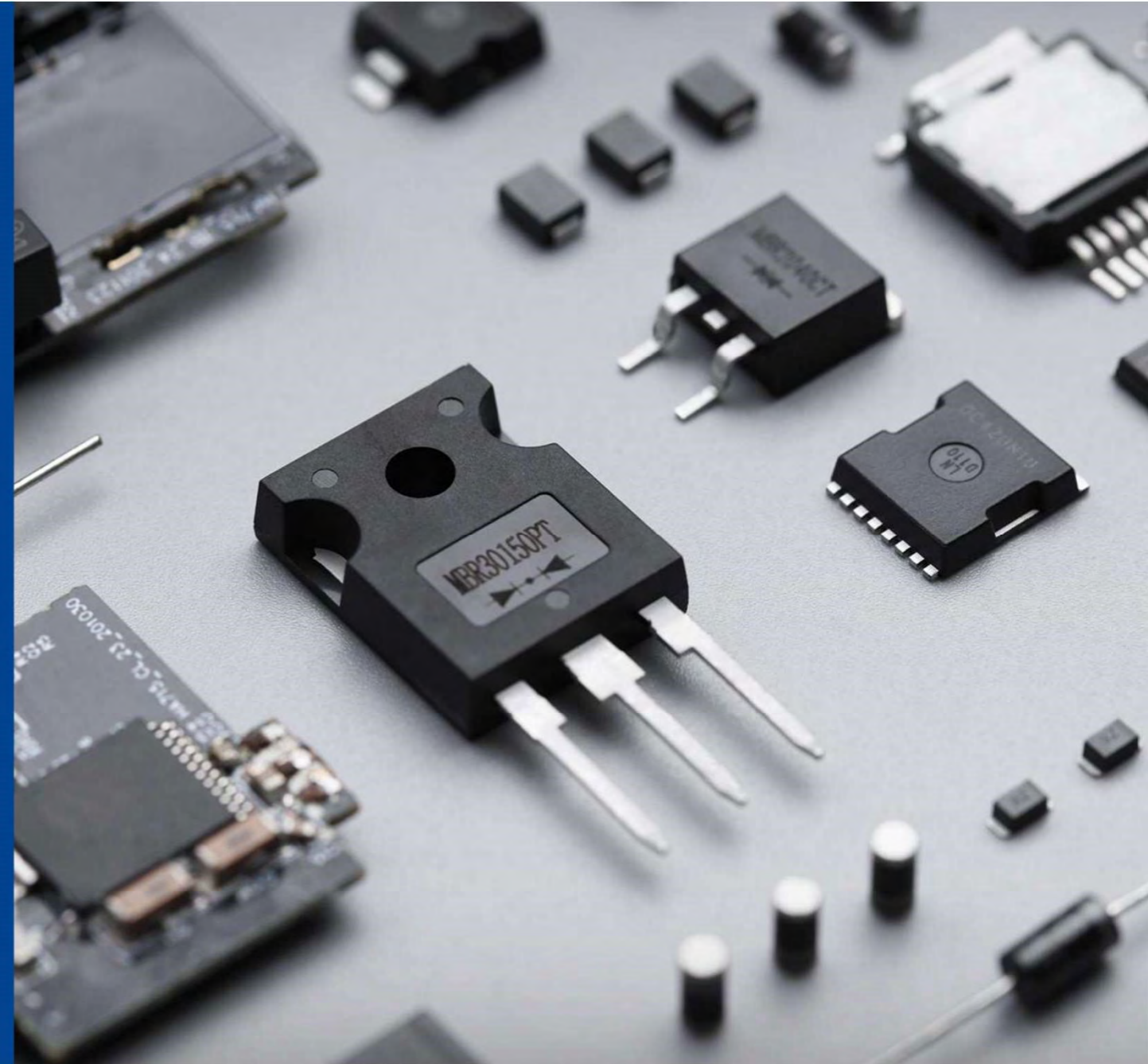

A PARTNER YOU CAN TRUST | [www.holystone.com.tw](http://www.holystone.com.tw)

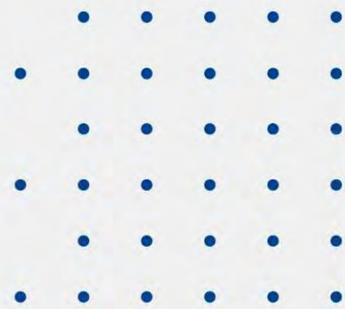



# PACKAGE PORTFOLIO ESD PROTECTION DEVICES



Package	VRWM	VRWM	CJ
	(Max)V	(Min)V	Typ.(pF)
<b>SOD-323F</b>	36	3.3	0.6~450
<b>SOD-523FL</b>	36	3.3	0.25~100
<b>SOD-923FL</b>	5	5	0.5~8
<b>SOT-143</b>	70	3.3	0.6~2.5
<b>SOT-23</b>	36	3.3	0.25~200
<b>SOT-23-6</b>	5	3.3	8
<b>SOT-323</b>	24	5	1.5~10
<b>SOT-353</b>	5	5	22
<b>SOT-363</b>	5	5	0.6~90
<b>SOT-523</b>	5	5	0.6~8
<b>SOT-723</b>	5	5	0.7
<b>SOT-553</b>	5	5	8
<b>SOT-563</b>	5	5	0.6~55

Package	VRWM	VRWM	CJ
	(Max)V	(Min)V	Typ.(pF)
<b>SOP-8</b>	24	2.8	1
<b>T0603</b>	36	1	0.13~25
<b>T1006P2</b>	36	2.5	0.15~245
<b>T1006P3</b>	5	5	0.45~1
<b>T1210P6</b>	5	5	0.2
<b>T1608P2</b>	24	24	16
<b>T1610P2</b>	36	2.5	125~860
<b>T1610P6</b>	5	5	0.3
<b>T2020P3</b>	24	15	750~1245
<b>T2510P10</b>	5	1.5	0.18~0.7
<b>T2626P10</b>	3.3	3.3	3.8
<b>T3020P10</b>	2.5	2.5	3.6
<b>T35135P14</b>	5	5	0.6



# MOSFET PORTFOLIO

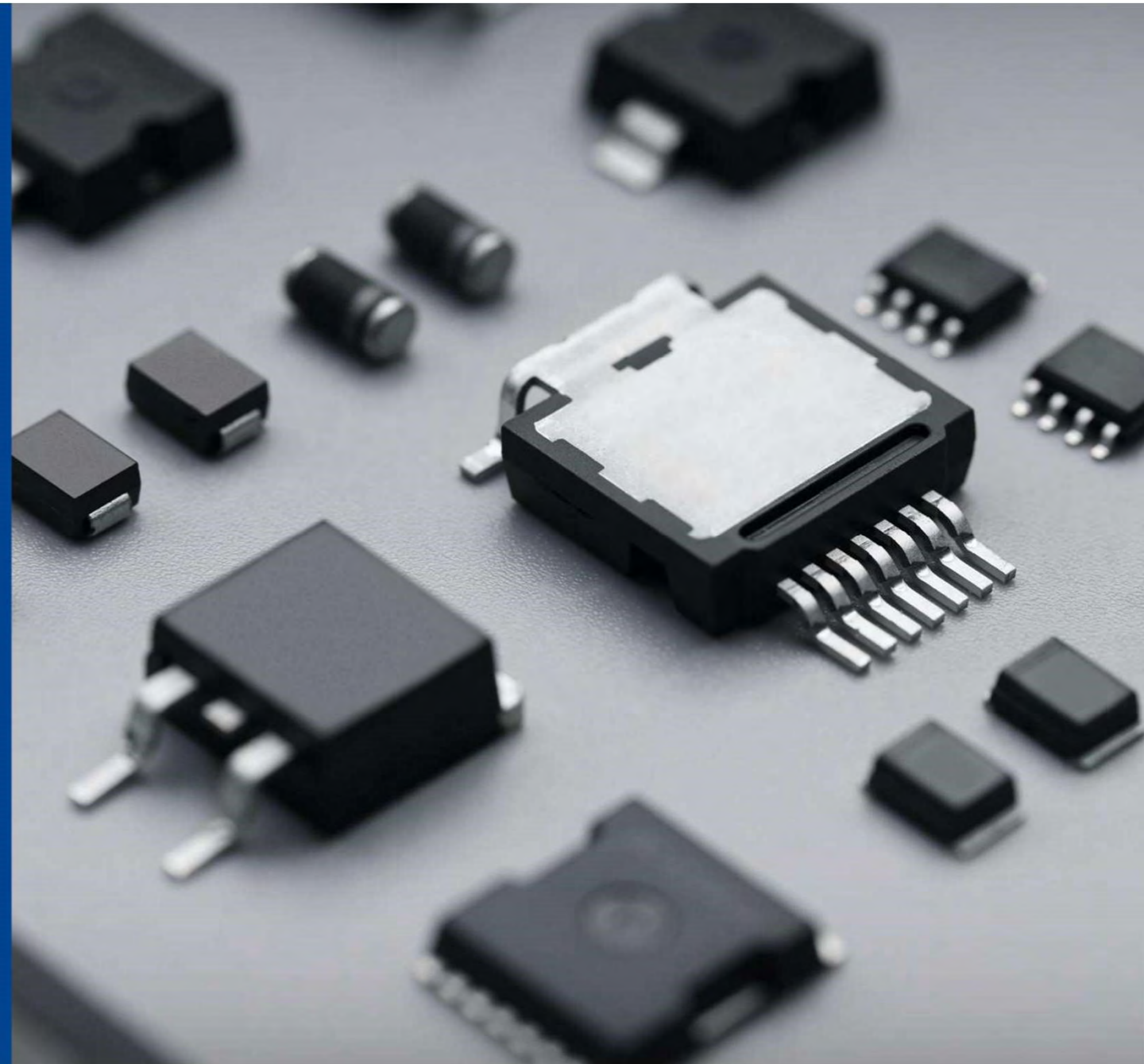

A PARTNER YOU CAN TRUST | [www.holystone.com.tw](http://www.holystone.com.tw)

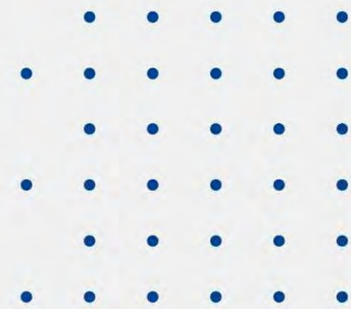



# PACKAGE PORTFOLIO MOSFET



T5060P8	T3333P8	TO-251S	T2020P6	T3030P8
TO-220AB	T1006P3	TO-247	TO-220AS	TO-251
TO-252 (DPAK)	TO-263 (D2PAK)	TSSO P-8	SC-59	SOP8 (SOP-08)
SO T-723	SO T-523	SO T-563	SO T-23	SO T-23-3L
SO T-23-6	SO T-323	SO T-363	SO T-223	SO T-89
TOLL	LFPAK	CSP		

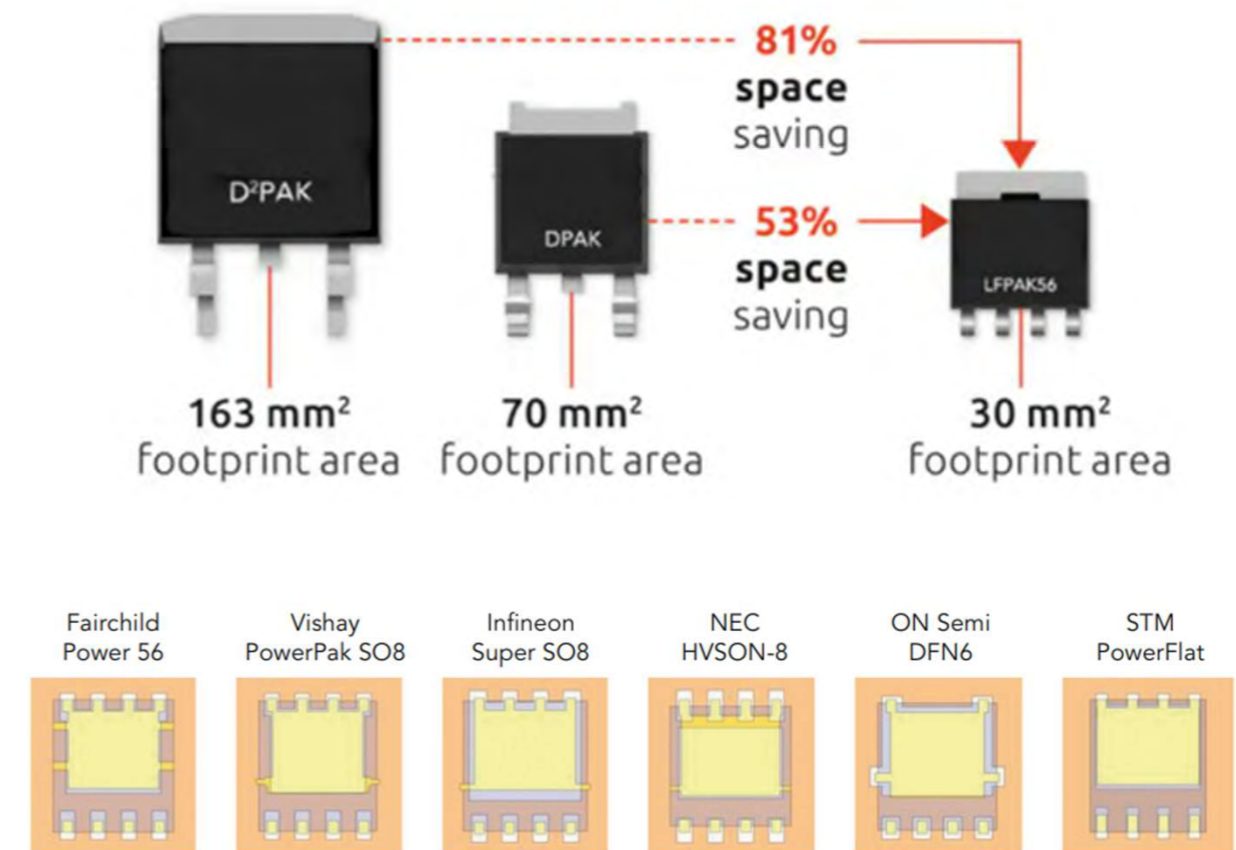

# HOLY STONE'S MOSFET PORTFOLIO

## COMPREHENSIVE RANGE OF PRODUCTS

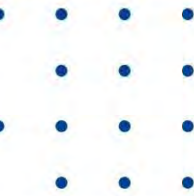

The MOSFET portfolio covers a wide range of voltage ratings, from 12V to 1500V, ensuring that there is a solution for every application, whether it's for low-voltage consumer electronics or high-voltage industrial systems.

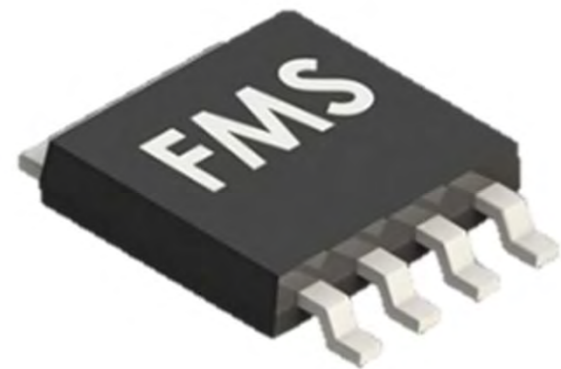

With options available in Trench, Planar, and Super Junction technologies, you can choose the most suitable MOSFETs for their specific performance needs, such as efficiency, speed, and power density.

MOSFETs with ultra-low  $R_{DS(on)}$ , minimizing conduction losses and improving overall efficiency in power conversion applications. This is particularly beneficial for applications such as SMPS, DC-DC converters, and motor drives where efficiency is critical.





# HOLY STONE'S MOSFET PORTFOLIO



## Flexible Packaging Options

- The MOSFETs are available in a variety of packages, including DFN, SOTx, TO-220, D2PAK, SOP8, and others, providing flexibility in design and enabling integration into various form factors.
- For applications requiring compact designs, the portfolio offers small signal MOSFETs in miniature packages like SOT-23 and SOT-223, perfect for space-constrained applications.

## Cost-Effective Solutions

- The portfolio offers a balanced mix of performance and cost-effectiveness, making it possible for customers to optimize their designs without compromising on quality or budget. This is particularly advantageous for manufacturers looking to maintain competitive pricing in the market.
- The use of advanced manufacturing processes ensures that even high-performance MOSFETs are available at competitive prices, making them accessible to a wide range of customers.



# HOLY STONE'S MOSFET PORTFOLIO



## Comparison 60V, 80A DPAK (TO-252)

Parameter	HolyStone/FMS	Dxxx	Txxx	Ixxx
Reference	FMOSU80N06A-HS	DMNH6012LK3	TSM120N06LCP	IRFR1018E
Voltage	60V	60V	60V	60V
ID	80A	80A	70A	79A
RDSon	0.0085	0.012	0.012	0.0084







# PRODUCT ROADMAP

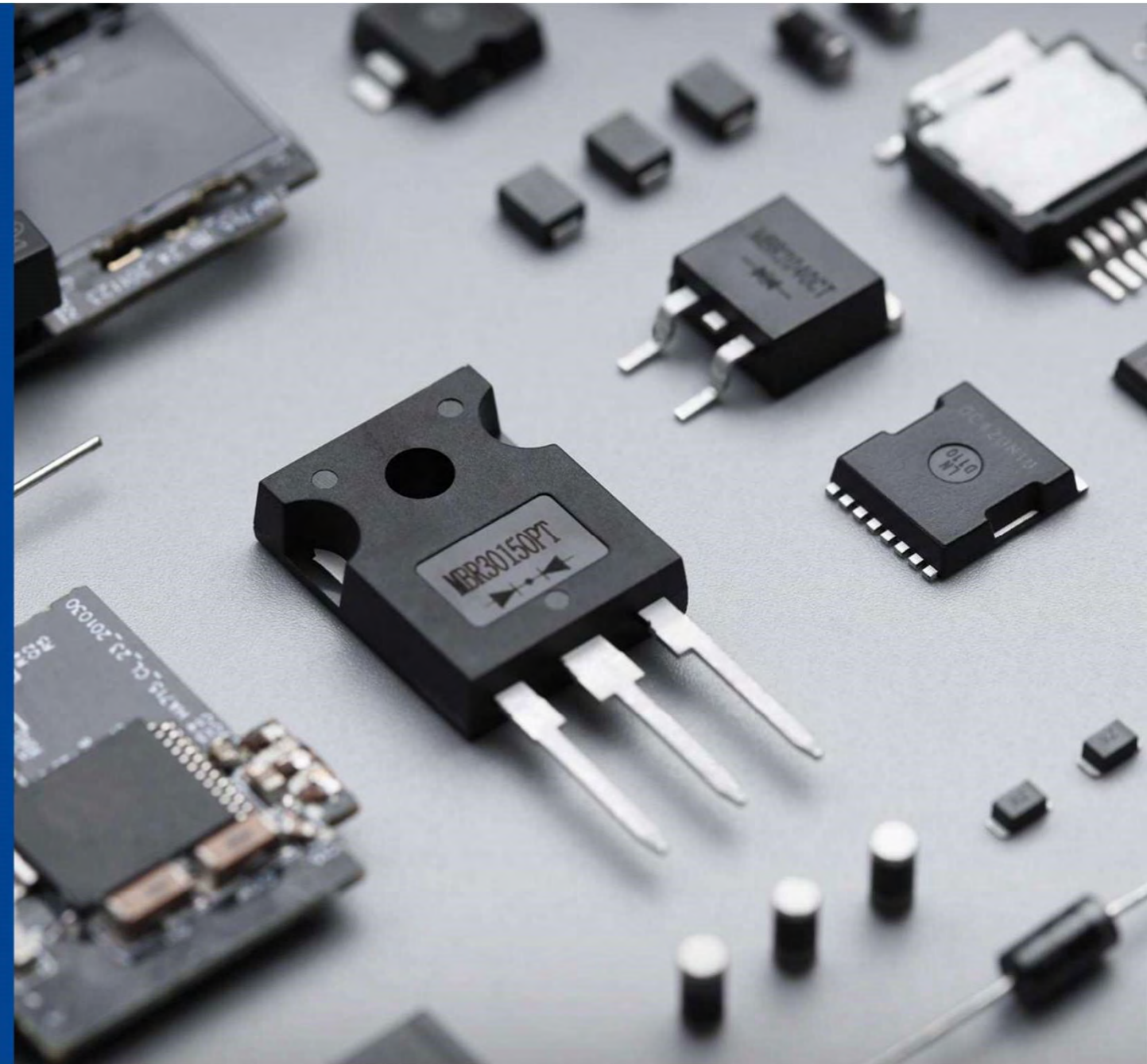

A PARTNER YOU CAN TRUST | [www.holystone.com.tw](http://www.holystone.com.tw)

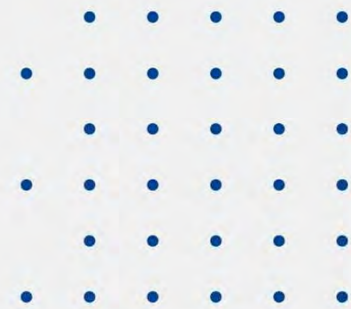

# PRODUCT ROADMAP

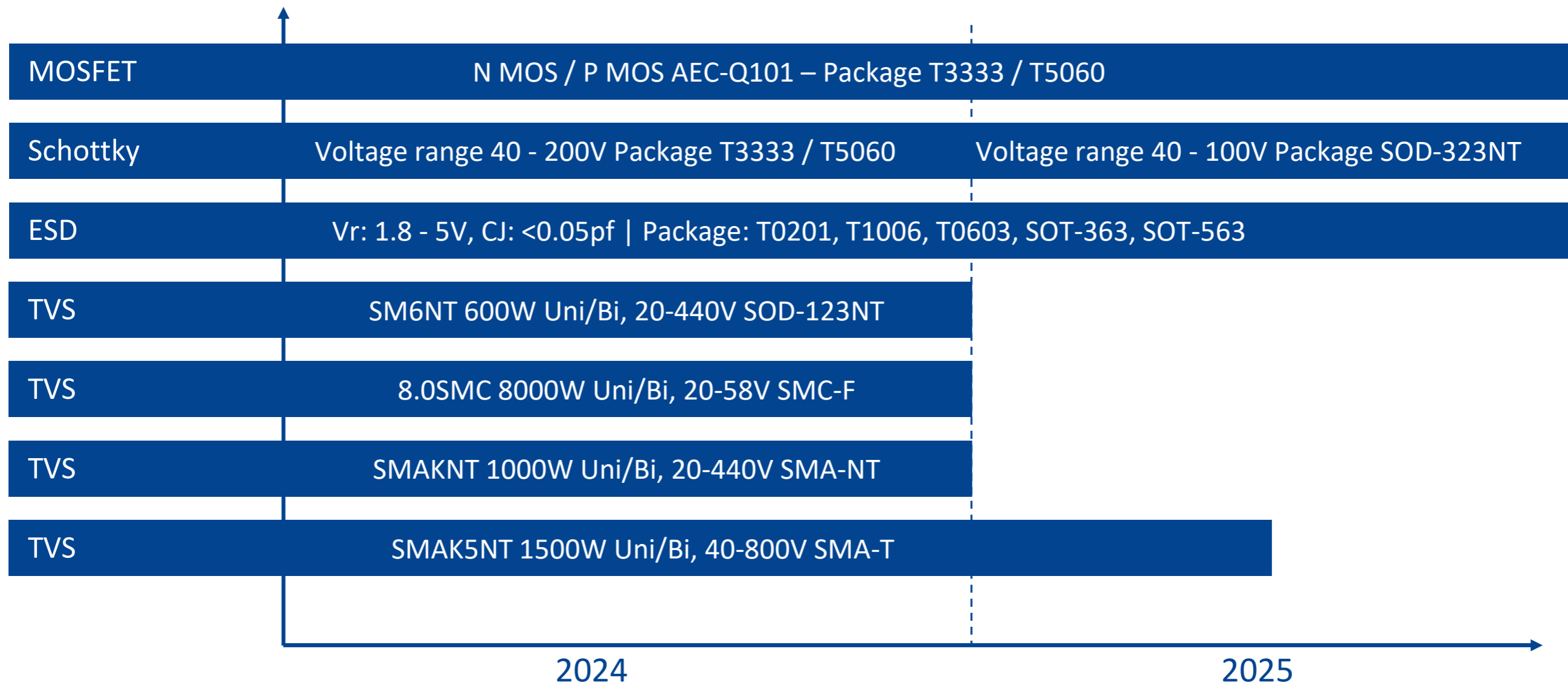



# PRODUCT ROADMAP

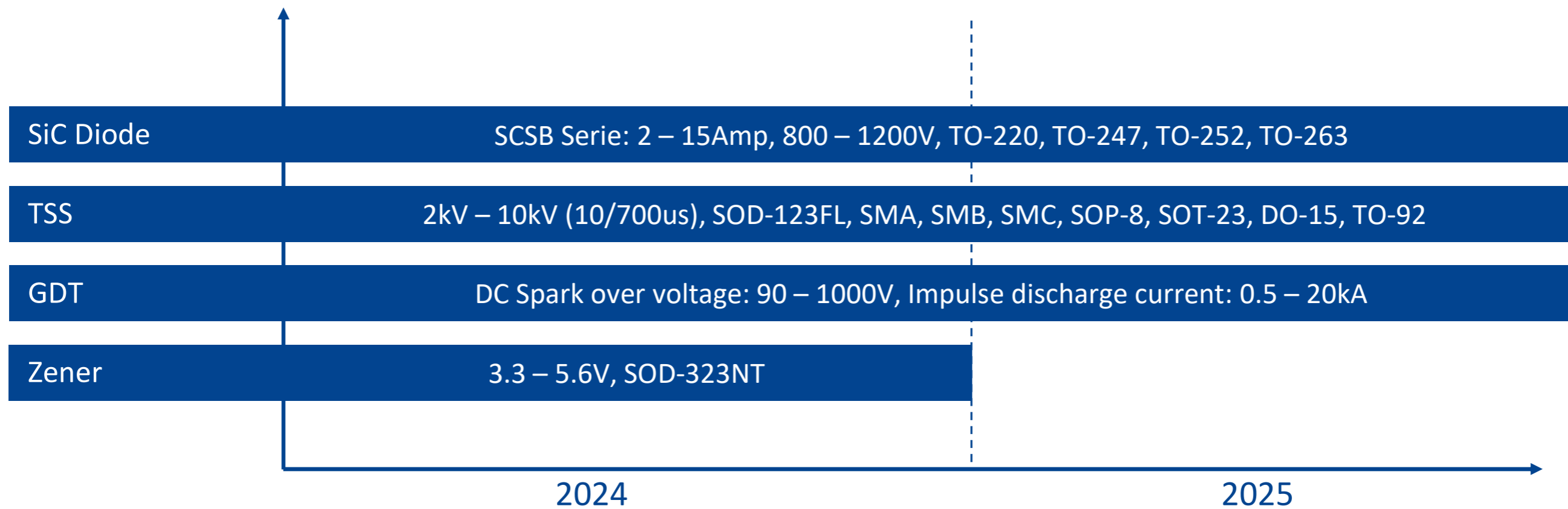



# CUSTOMER APPLICATIONS

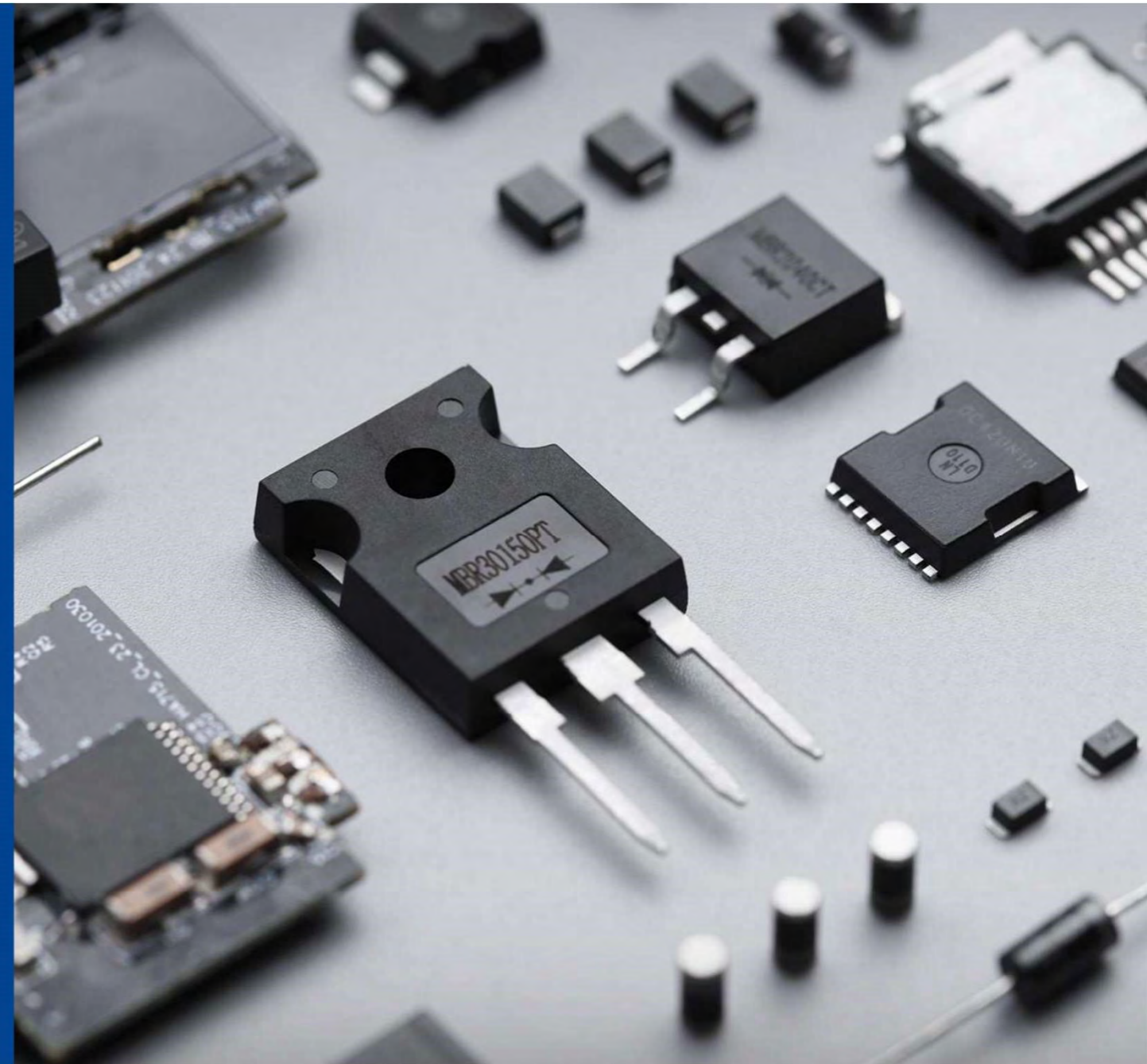

A PARTNER YOU CAN TRUST | [www.holystone.com.tw](http://www.holystone.com.tw)

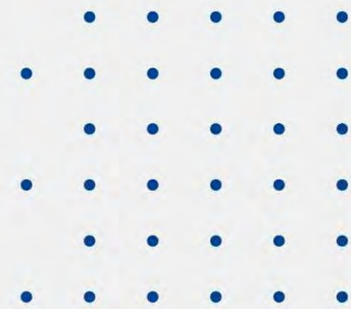





## HOLY STONE HAS THE RIGHT PORTFOLIO FOR INVERTER AND BATTERY MANAGEMENT

- HIGH VOLTAGE MOSFETS
- SIC DIODE & SIC MOSFETS
- TVS, ESD, RECTIFIER AND BRIDGE RECTIFIER
- SAFETY CAPACITOR X/Y
- MLCC (GENERAL PURPOSE, HIGH VOLTAGE AND HIGH CAPACITANCE)

### APPLICATIONS:

- MPPT, BMS, CONVERTER, INVERTER,







## HOLY STONE'S PORTFOLIO FOR AUTOMOTIVE

- SIC DIODE & SIC MOSFETS
- TVS, ESD, RECTIFIER AND BRIDGE RECTIFIER
- SAFETY CAPACITOR X/Y
- MLCC (AUTOMOTIVE GRADE ACC SERIES)

### APPLICATIONS:

- CHARGING STATION, OBC, DC/DC, PFC, BMS, INVERTER







# HOLY STONE'S PORTFOLIO FOR AUTOMOTIVE

## SIC Diode

Part Number	Vrrm(V)	IF(A)	Package
FSC3065PCTW-HS	650	15	TO-247AB
FSC30120PCTW-HS	1200	15	TO-247AB
FSC10170PW-HS	1700	10	TO-247AC

## Planar MosFET

Part Number	CH	$V_{DS\_Max}$ (V)	$I_{D\_Max}$ (A)	Package
FMOSPF07N65D-HS	N	650	7	ITO-220AB
FMOSCDP30N65-HS	N	650	30	ITO-220AB
FMOSPRPF12N65-HS	N	650	12	ITO-220AB

## SGT MosFET

Part Number	CH	$V_{DS\_Max}$ (V)	$I_{D\_Max}$ (A)	Package
FMOSP270N10-HS	N	100	270	TO-220AB
FMOSPW287N10-HS	N	100	287	TO-247
FMOSP258N10-HS	N	100	258	TO-220AB

## TVS Protection

Power W	Uni	Part Number	Bi	Package
6600	SM8S12/24/36CA-Q1-HS	SM8S12/24/36A-Q1-HS		DO-218
7500	ASM7.5KP12/24/48CA-Q1-HS	ASM7.5KP12/24/48A-Q1-HS		ASM-10A

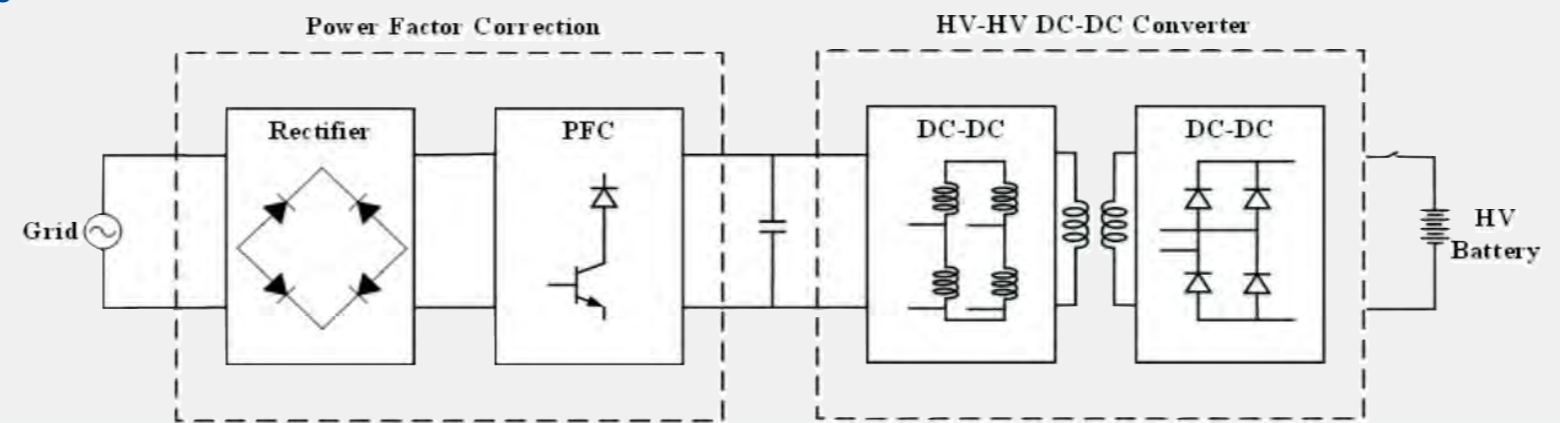





## HOLY STONE PORTFOLIO TO MEET INDUSTRIAL AUTOMATION NEEDS

- MOSFETS
- SIC DIODE & SIC MOSFETS
- TVS, ESD, RECTIFIER AND BRIDGE RECTIFIER
- SAFETY CAPACITOR X/Y
- MLCC (GENERAL PURPOSE, HIGH VOLTAGE AND HIGH CAPACITANCE)

### APPLICATIONS:

- MOTOR CONTROL, PLC, HMI, IPC, POWER SUPPLY

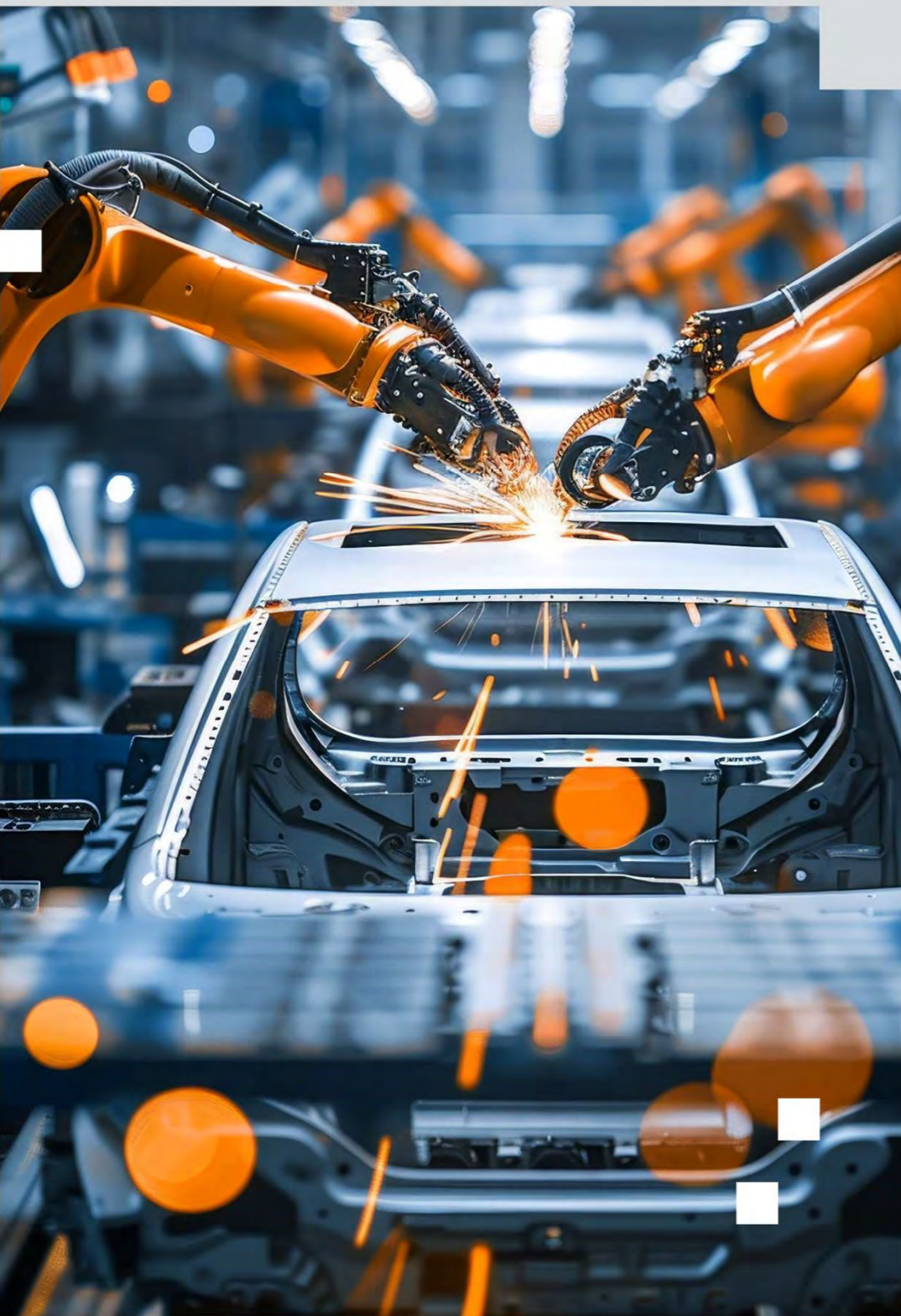





# HOLY STONE HAS THE RIGHT PORTFOLIO TO PROTECT YOUR DEVICES

- TVS DIODES
- ESD PROTECTION DEVICES
- THYRISTOR SURGE SUPPRESSOR
- GAS DISCHARGE TUBES

## APPLICATIONS:

- CONSUMER, AUTOMOTIVE, INDUSTRIAL, MEDICAL











**Holy Stone**

## **Bastian Siebenhaar**

Director, Semiconductor

---

### ***Holy Stone Enterprise Co., Ltd.***

1F, No. 62, Sec. 2, Huanshan Rd., Neihu Dist.,  
Taipei 11452, Taiwan, R.O.C.

**Mobile:** 886-972722975

**Fax:** 886-2-2627-0242

**Email:** [bastian@holystone.com.tw](mailto:bastian@holystone.com.tw)

[holystone.com.tw](http://holystone.com.tw)

## European Sales Channel



Philipp Kappes  
Managing Director

+49 9122 8768-15

[Philipp.kappes@rm-components.de](mailto:Philipp.kappes@rm-components.de)





# THANK YOU

